

8. SPR Series (Unshielded Type)

Applications

DC/DC converters, etc.  
Other various electronic appliances.

Features

Silver plated type, low cost design.  
Available on tape and reel for auto surface mounting.



Inductance and Rated Current ranges

Part Series	Inductances range	Rated Current range
* SPR0301	1.0~390μH	1.40~0.10A
* SPR0302	1.0~470μH	2.20~0.070A
* SPR0403	1.0~1000μH	2.70~0.109A
* SPR0502	1.0~1000μH	4.00~0.14A
* SPR0503	1.0~1000μH	4.50~0.13A
* SPR0504	1.0~1000μH	5.00~0.26A
* SPR0703	1.0~1000μH	1.64~0.20A
* SPR0705	1.0~1000μH	3.40~0.30A

(Dimension data (Refer to Fig. 1))

Part Series	Inductances range	Rated Current range
* SPR0603	1.5~470μH	3.0~0.15A
* SPR0604	1.2~820μH	4.2~0.14A
* SPR0805	1.5~4700μH	6.0~0.08A
* SPR1006	1.5~4700μH	6.4~0.10A

(Dimension data (Refer to Fig. 2))

Characteristics

Rated DC Current :

The inductance becomes 10% lower than its initial value or temperature of coil increases to T=40 . (Ta=25 )

Operating temperature range : -40 ~+125 .

Test equipment (Electrical specifications at 25 ) :

L: HP4284A LCR meter; DCR: Milli-ohm meter.

Part Numbering System

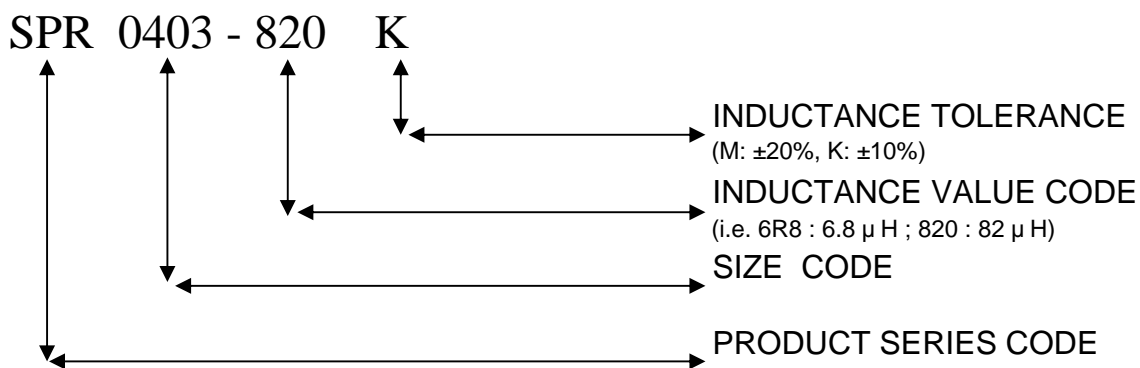

8. SPR Series (Unshielded Type)

**Dimensions (mm)**

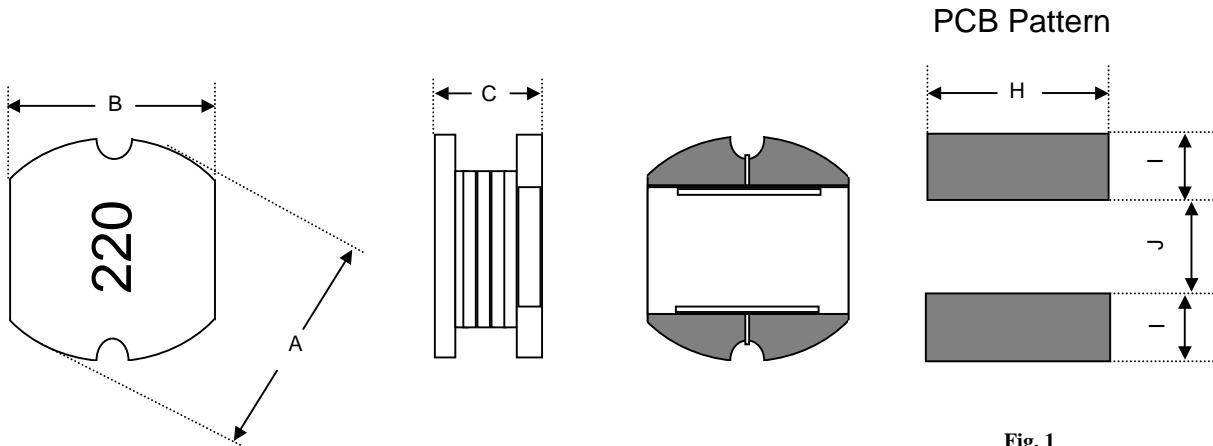

Fig. 1

Series	A	B	C (Max.)	H	I	J
SPR0301	3.5±0.3	3.0±0.3	1.45	3.50	1.60	0.8
SPR0302	3.5±0.3	3.0±0.3	2.40	3.50	1.60	0.8
SPR0403	4.5±0.3	4.0±0.3	3.50	4.50	1.75	1.5
SPR0502	5.8±0.3	5.2±0.3	2.80	5.50	2.15	1.7
SPR0503	5.8±0.3	5.2±0.3	3.30	5.50	2.15	1.7
SPR0504	5.8±0.3	5.2±0.3	4.80	5.50	2.15	1.7
SPR0703	7.8±0.3	7.0±0.3	4.00	7.50	3.00	2.0
SPR0705	7.8±0.3	7.0±0.3	5.50	7.50	3.00	2.0

8. SPR Series (Unshielded Type)

Electrical Characteristics

SPR 0301 / 0302 / 0403 TYPE

Inductance value code	L (μH)	DC Resistance ( ) Max.			Rated DC current (A) Max.		
		0301	0302	0403	0301	0302	0403
1R0	1.0	0.060	0.045	0.049	1.400	2.200	2.700
1R2	1.2	-	0.050	0.053	-	2.100	2.540
1R4	1.4	-	0.050	0.056	-	2.000	2.500
1R5	1.5	0.081	0.055	0.061	1.300	1.700	2.240
1R8	1.8	0.098	0.070	0.064	1.240	1.650	2.330
2R2	2.2	0.240	0.085	0.072	1.200	1.600	2.250
2R7	2.7	0.135	0.100	0.079	1.040	1.400	2.160
3R3	3.3	0.270	0.120	0.086	1.000	1.040	2.000
3R9	3.9	0.188	0.130	0.094	0.790	1.000	1.840
4R7	4.7	0.400	0.170	0.109	0.900	1.000	1.620
5R6	5.6	0.450	0.185	0.126	0.650	0.950	1.480
6R8	6.8	0.500	0.200	0.131	0.560	0.950	1.430
8R2	8.2	0.650	0.250	0.147	0.500	0.900	1.370
100	10	0.750	0.320	0.182	0.450	0.760	1.040
120	12	0.850	0.350	0.210	0.430	0.685	0.970
150	15	1.200	0.460	0.235	0.390	0.635	0.850
180	18	1.300	0.520	0.338	0.320	0.525	0.740
220	22	1.500	0.660	0.378	0.280	0.500	0.680
270	27	2.200	0.760	0.522	0.260	0.405	0.620
330	33	2.800	0.920	0.540	0.250	0.380	0.560
390	39	-	1.120	0.587	-	0.355	0.520
470	47	4.000	1.270	0.844	0.210	0.330	0.440
560	56	4.500	1.500	0.937	0.200	0.290	0.420
680	68	5.000	2.000	1.117	0.180	0.260	0.370
820	82	6.500	2.440	1.140	0.160	0.230	0.340
101	100	7.500	2.850	1.190	0.150	0.200	0.300
121	120	-	3.400	1.400	-	0.180	0.256
151	150	-	4.470	1.800	-	0.160	0.212
181	180	-	5.110	1.920	-	0.150	0.200
221	220	14.000	7.310	2.030	0.130	0.140	0.180
271	270	-	8.500	2.890	-	0.100	0.174
331	330	22.000	10.19	3.760	0.110	0.090	0.168
391	390	26.000	-	4.260	0.100	-	0.160
471	470	-	13.50	5.140	-	0.070	0.158
561	560	-	-	6.370	-	-	0.148
681	680	-	-	9.240	-	-	0.128
821	820	-	-	13.400	-	-	0.110
102	1000	-	-	15.600	-	-	0.109

- Test Frequency :  
**SPR0301** : 1.0μH~8.2μH @100KHz 0.25V, 10μH~390μH @1KHz 0.25V  
**SPR0302, SPR0403** : 1.0μH~8.2μH @100KHz 0.25V, 10μH~1000μH @1KHz 0.25V
- Tolerance of Inductance :  
**SPR0301** : 1.0μH~390μH (M)±20%  
**SPR0302, SPR0403** : 1.0μH~8.2μH (M)±20% , 10μH~1000μH (K)±10% , (M)±20%
- Rated DC Current : the inductance becomes 10% lower than its initial value or temperature of coil increases to T=40 . (Ta=25 )
- Operating temperature range : -40 ~+125 .